



Instructions

QuickScan[®] QS6500BT Table Mount and QuickScan[®] QS6500BT Wall Mount

Preparing to Install the Mount

1. Determine the best location to mount the Base Station. Some considerations are:
 - Proximity to the host device. Verify that the Base Station will be mounted within a reasonable distance of the host, and that cabling can be routed between the devices without kinking, stretching or exposing cabling to tampering or other portential damage.
 - Mounting stability. Avoid mounting the unit in such a way as to subject it to excess vibration, bumping, spillage, etc.
 - Ensure the Base Station will be mounted in such a way as to allow best radio (BlueTooth) communication between the station and its linked imager. (No adjacent metal objects or thick barriers, provide reasonable line of sight, install within optimal operating distance, etc.)
2. Use the appropriate template (Table Mount or Wall Mount) from the next page to locate and mark the position of the screw holes needed for your installation.
3. The methods described below are general guidelines outlining easy ways to install the mounts. The accessories have been designed, however to allow flexibility for numerous configurations you may wish to try.

Installing the Table Mount

Use this set of instructions for horizontal (tabletop surface) installations. Proceed to the next section if installing to a vertical (wall) surface.

1. Screw the mount to the Base Station using two M3 screws. *Alternatively, install two M3 machine screws into the bottom of the Base Station and leave the screw heads protruding by two to three threads. It will be secured to the mount later, as described in step 4.*
2. Secure the mount to the table using two self-tapping M4 or #8 screws.
3. The cable can be optionally routed as shown; up through a hole in the table and out through the underside of the mount.
4. *If the mount is not screwed to the Base Station already, insert the screw heads (protruding beneath the Base Station) into wide end of the mount's "keyhole" openings. Rotate the Base Station clockwise to secure it in position. It can be removed by reversing this process.*
5. Carefully pull the cable through to remove any extra slack.

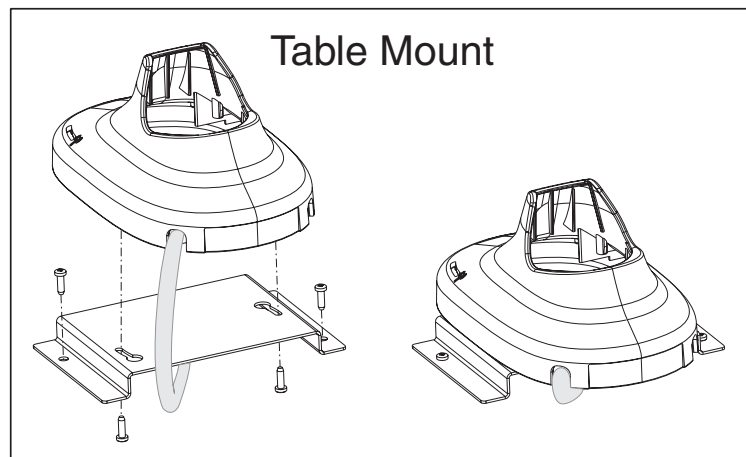

Installing the Wall Mount

Use this set of instructions to install to a vertical (wall) surface. Use the instructions on the previous page if installing to a horizontal (tabletop surface).

1. Secure the mount to the wall using two M4 or #8 screws. As shown in the Wall Mount Template, you can optionally install the screws through the mount's drilled holes in alternate position #1, or you can install screws in alternate position #2 which allows notches in the mount to be slid down onto the screw heads (which for this purpose are left protruding by two to three threads).
2. Secure the Base Station to the mount using two M4 or #8 machine screws.

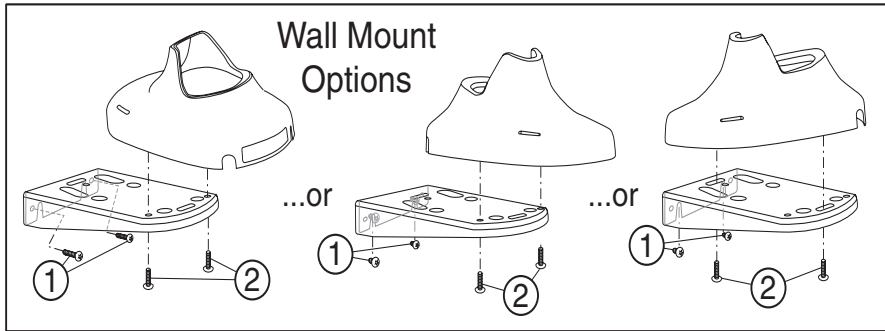

NOTE

Openings in the mount are provided for flexible mounting options, plus to accommodate the pads on the underside of the Base..

Mount Templates

